



HT-250 Rotary valve



HT-250 Rotary valves are used for transferring dry powders and granulates out of filter housings, cyclones, silos and hoppers. The rotary valves can also be used for discharging dry, powdered or granulated products from a storage hopper or silo into a mixer, grinding mill, conveyor screw, dryer or cooler or, in some cases, for discharging into a pneumatic transport system. In most of the above-mentioned applications, besides serving as a discharging component, the HT-250 rotary valves also function as an air lock, to maintain a certain pressure differential in the system. The versions with Vulkollan rotorblades are suitable for use with product temperatures up to 60°C, the versions with metal rotorblades up to 80°C and the heat resistant versions up to 200°C. Depending on the choice of drive system the rotary valve is suitable for use in an ambient temperature up to 40°C.



HT-250 Rotary valve

FEATURES STANDARD VERSION

Body and covers	: Cast iron GG25
In- and outlet	: Ø= 250 mm
Rotorconstruction	: Open, with 6 or 8 chambers
Driveunit	: Direct, with flexible coupling and gearmotor NORD 0,37 kW 230/400V, 50 Hz. IP55, iso F
Rotation speed	: 31 rpm
Finishing	: - In- and outlet painted in color RAL 3020 (red) - Body, covers and motorconsole painted in color RAL 5009 (blue) - Other RAL colors available at surcharge
Sealing	: 6 Plastic blades, thickness 3 mm: feltring and sealing 6 Springsteel or stainless steel blades: feltring, bronze bush and sealing 8 Polyurethane blades, thickness 4 mm: bronze bush and sealing, no feltring. Rotor: heavy welded version
Bearings	: Sintered bronze bearings, self-lubricating
Max. operating pressure	: 5.000 Pa (500 mmWK), with 8 blades: 10.000 Pa (1.000 mmWK)
Temperature	: -15° up to 60°C (with stainless steel- and springsteel: 80°C)
Capacity	: ca. 7 liter / rev (100% filling)

ROTORS

	
St.eel37 / Nylon	Steel 37 / Vulkollan 3 mm
	
St.eel37 / Springsteel	Stainless steel 304 / Vulkollan 3 mm
	
Stainless steel 304 / Stainless steel 304	S355 / Vulkollan 4 mm / 8 blades

PROFILE

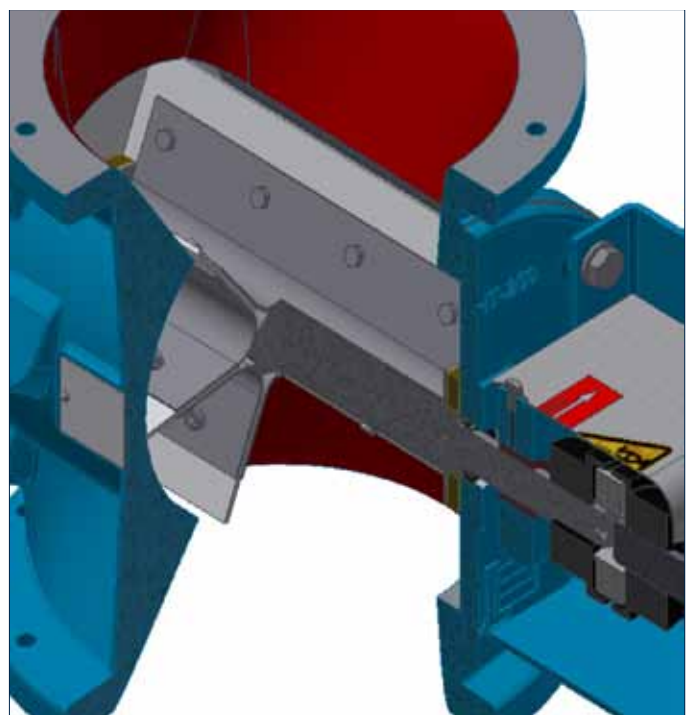







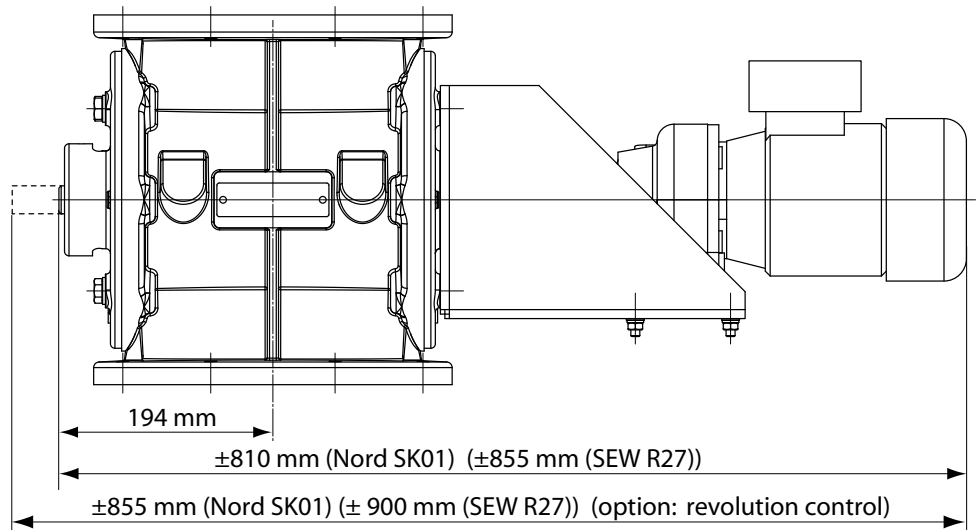
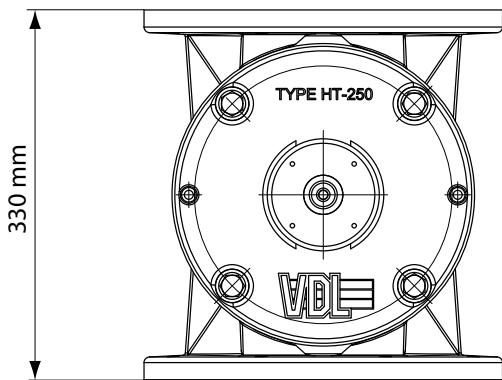
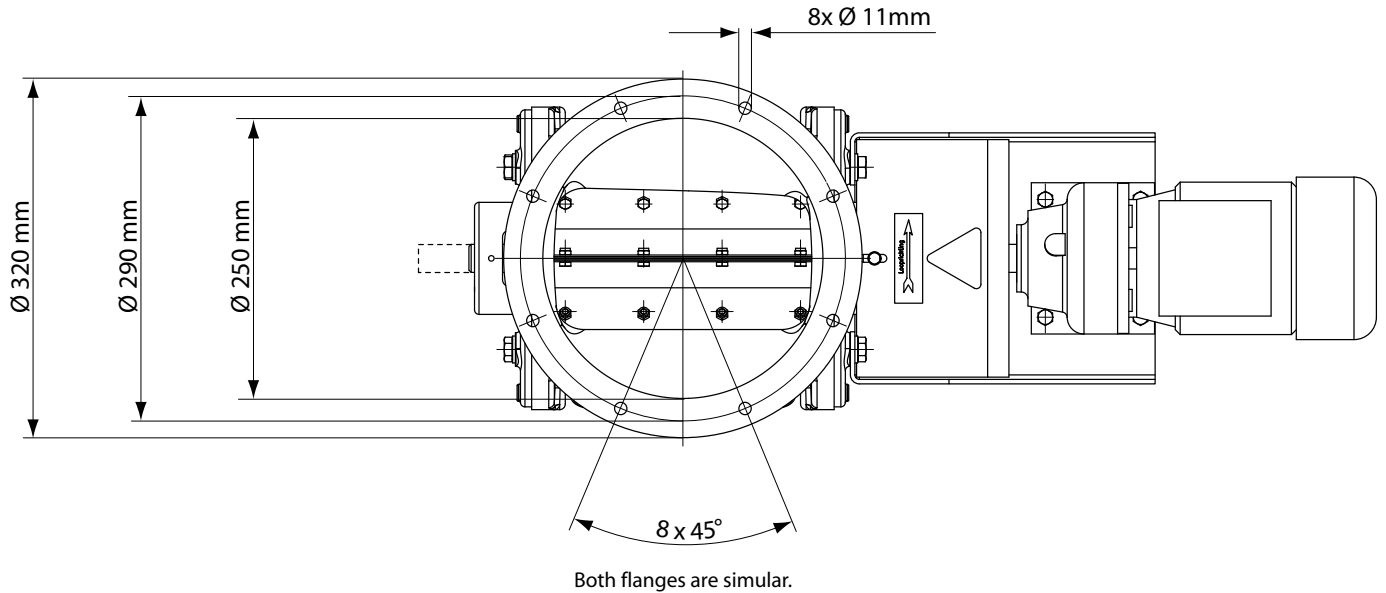



VDL Industrial Products

HT-250 Rotary valve



OPTIONS

						
Garmotors	Different color					
						
Blades	Chromium plating	Chemically nickel plated	Revolution speed	Operating switch	Gasket & flange	Isolation



VDL Industrial Products bv
Hoevenweg 3, 5652 AW Eindhoven
P.O. Box 8822, 5605 LV Eindhoven
The Netherlands

Phone +31 (0)40 292 55 80
Fax +31 (0)40 292 55 02
info@vdlindustrialproducts.com
www.vdlindustrialproducts.com